

Installation
Operation
Maintenance
Troubleshooting
Version Dec/17



Table of Contents

WARRANTY	3
Important Information.....	4
Operator’s Instructions.....	5
1414 Mini Control Flow Diagram	6
Purging Your System.....	7
Troubleshooting Guide	8
Installation Instructions.....	9
Utility Center Plumbing Layout.....	10
Utility Center Tubing Diagram.....	11

WARRANTY

Summit Dental Systems (SDS) warrants its products against defects in materials or workmanship from the date of shipment to the Buyer as follows:

Summit Dental Systems (SDS) Equipment:

Chairs, Delivery Units, Cuspidors, Lights
 Control Block Diaphragm (part of Delivery Unit)
 All Upholstery, Stools, all Plastic Covers, and Cabinets

Warranty Period:

5 Years
 Lifetime
 1 Year

Summit Dental Systems' sole obligation under the warranty is to provide parts for repair, or at its option, to provide a replacement product (excluding all labor and shipping fees). "In any action, BUYER'S remedies are limited to the warranty described above. BUYER shall not be permitted to claim lost profits, reliance, special, incidental, or consequential damages in any proceedings." The warranty does not cover damage from improper installation or maintenance, accident or misuse. The warranty does not cover damage resulting from the use of cleaning disinfecting or sterilization chemicals and processes. Failure to follow instructions provided in Summit Dental Systems' Operation and Installation Manuals (Owner's Guides) may void the warranty. In the event Warranty service must be performed to correct any defect, only an authorized Summit Dental System dealer may perform any and all warranty repairs. Any repairs by unauthorized dealers, technicians, or repairmen may void the warranty.

- In the case of a defective warranty item, a copy of the replacement invoice, model and serial number of the product under which it was replaced, and a description of symptoms of the defect must be returned with the part within 30 days of the replacement invoice date to Summit Dental Systems, 1280 SW 27th Ave Pompano Beach, FL 33069, USA, in order to receive credit. Any and all expenses for freight, labor to perform warranty service, and purchase of spare parts are the responsibility of the buyer. Any fraudulent claims made may void the warranty. Any additional warranty that may be provided by an authorized Summit Dental Systems dealer is the sole responsibility of said dealer.



- SDS reserves the right to make changes or improvements on any products without being required to modify existing equipment in a like manner.

Please complete and retain for your records the following Information:

In case of warranty part replacement/repair or when ordering a part, please call your authorized Summit Dental Systems dealer and have the following information available:

Model #:	SDS Serial #:
Dealer:	Phone:
	Purchase Date:

Important Information

Technical Specifications

Air Regulator Pressure: 80 PSI

Water Regulator Pressure: 40 PSI

**Handpiece Pressure: 30-35 PSI (for most high-speed handpieces)
 40-45 PSI (for most low-speed handpieces)**

CAUTION: When adjusting the handpiece pressure, do not over tighten the screws. This may result in unnecessary damage to the handpiece control block.

- Pay careful attention when unpacking the delivery unit and its accessories. *Damage caused by mishandling the equipment during unpacking or installation is not covered under warranty.*
- **New Owner:** Please read, sign and submit the warranty registration form that is located on page 4 of this manual. Failure to return this form may void the warranty.
- Read this manual carefully. If you have any questions, please call **SDS Technical Service** at **1-800-275-3368**.

Product Label Location

The product label can be located on underneath the unit head chassis.

SUMMIT DENTAL SYSTEMS Pompano Beach, FL USA		
MODEL No: _____		
SERIAL No: _____		
PRODUCT: _____		

VOLTS	HERTZ	AMPS

Operator's Instructions

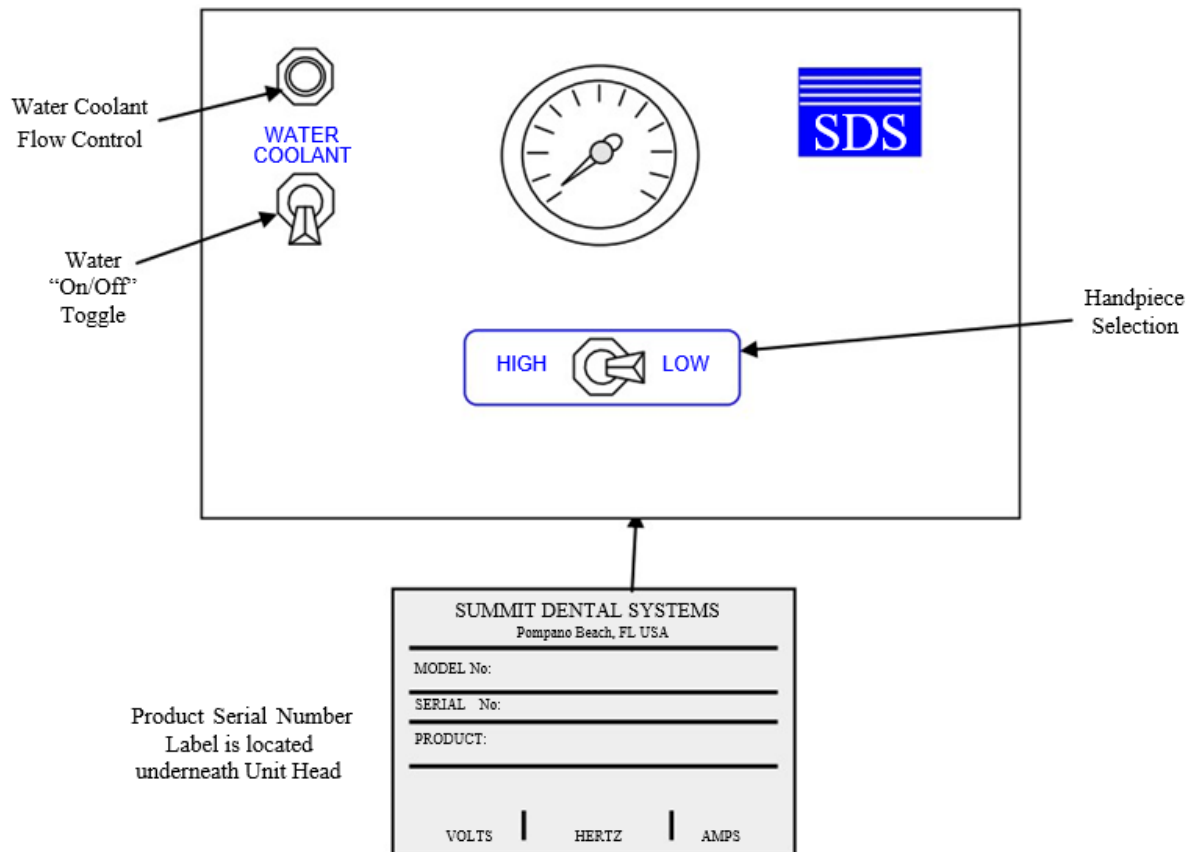

1. Turn the Handpiece Selection switch to the desired handpiece position.
 2. The handpieces are automatically activated when removed from their hanger.
 3. Depress the Foot Control to operate the activated handpiece. Pressure is shown on the gauge for the handpiece being used.
 - NOTE:** Individual handpiece pressure adjustments at the back of the drive air adjustment block, located inside the unit. To adjust the pressure to each handpiece, turn the adjustment screw clockwise to decrease pressure or counter-clockwise to increase pressure.
- CAUTION:** When adjusting the handpiece pressure, do not overtighten the screws. This may result in unnecessary damage to the handpiece control block.
4. To activate water spray turn the Water On/Off Toggle to the „On“ position. It is located on the left side edge under the control head. Flow adjustment to the „wet“ handpieces is controlled by the controls labeled „Flow Control“.

1414 Mini Control Flow Diagram

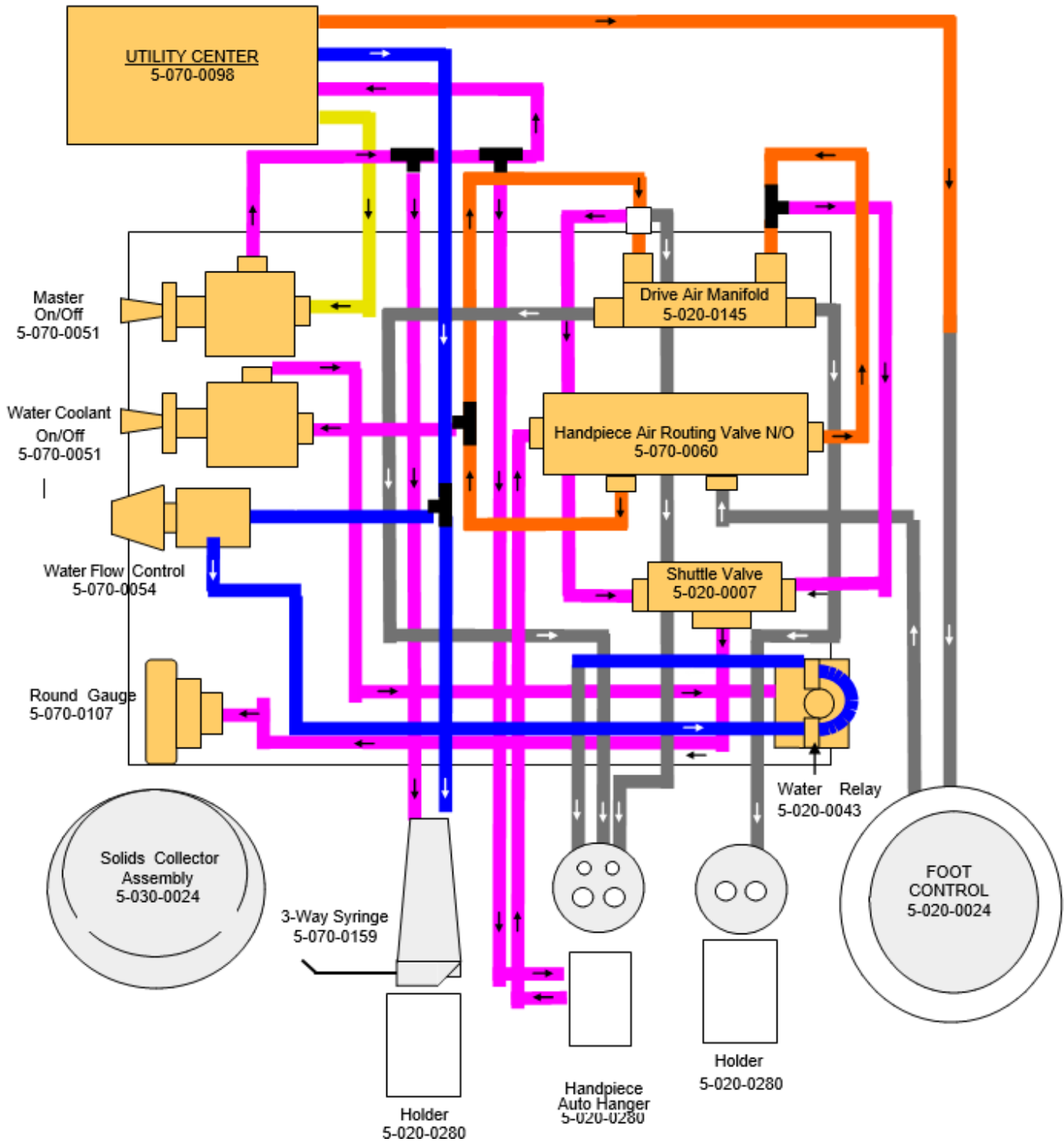

Purging Your System

Daily Maintenance

Purging with air: At the end of every day, the lines should be purged with air to prevent the growth of biofilm.

1. Remove handpieces from tubing.
2. Empty the water bottle, then reinstall it (if water bottle is applicable, when using city water, turn off water from the source).
3. Hold the handpiece tubing and syringe over a pail. Turn the unit on, wait a few moments and then operate the flush toggle (if applicable), syringe and foot control until water is purged from the system.
4. Turn unit off.

Disinfecting the bottle (if applicable): Fill the bottle with 100 ml disinfectant solution, shake vigorously and let settle for 10 minutes. Shake again, and then rinse

Weekly Maintenance

The weekly cleaning procedure should be performed at least once a week, preferably at the start of the week before treating patients. If the unit is stored for any length of time, perform the weekly maintenance routine immediately before and after storage.

1. Purge the unit with air (see Daily Maintenance).
2. Flush the system with disinfectant solution:
 - a. Turn unit off. Empty the water bottle (if water bottle is applicable), replacing the water with cleaning solution (see Disinfectant Solution).
 - b. Remove handpieces from tubing and hold the handpiece tubing and syringe over a pail. Turn unit on, wait a few moments and then operate the flush toggle (if applicable), syringe and foot control until a continuous stream of solution is running through the system.
3. Allow the disinfectant to remain in the unit for at least 10 to 20 minutes and then flush the system again until all the solution is used up.
4. Purge the unit with air:
 - a. Hold the handpiece tubing and syringe over a pail. Turn the unit on, wait a few moments and then operate the flush toggle (if applicable), syringe and foot control until all solution is purged from the system.
 - b. Turn unit off. (If the unit is to be stored, stop here.)
5. Fill with clean water:
 - a. With the unit turned off, remove the empty disinfectant bottle (if applicable). Replace with clean bottle and water.
 - b. Hold Remove handpieces from tubing and hold the handpiece tubing and syringe over a pail. Turn unit on, wait a few moments and then operate the flush toggle (if applicable), syringe and foot control until a continuous stream of solution is running through the system.

Disinfectant Solution: Use 100 ml (9 parts tap water & 1 part 5.25% Sodium hypochlorite (household bleach) of disinfectant solution for each application per week. Always use a fresh mixture every week.

Troubleshooting Guide

SYMPTOM

1. Handpiece Lacks Power

PROBABLE CAUSE

- A. Check regulator adjustment (80 psi).
- B. Check handpiece pressure adjustment on control block.
- C. Plugged air filter.
- D. Pinched supply tubing. Check for kinks.
- E. Bad handpiece gasket at connection with tubing.
- F. Defective handpiece.

2. Water coolant does not shut off when Foot Control is released.

- A. Adjust air pressure to 80 psi - water pressure to 40 psi.
- B. Foot Control is not exhausting.
- C. Defective water relay in valve

3. More than one handpiece is operating.

- A. Handpiece is not completely in the hanger.
- B. Improper adjustment of Pilot Valve in the hanger.
- C. Kinked or pinched signal line from the Pilot Valve.

4. Insufficient water coolant.

- A. Adjust coolant flow valve.
- B. Water filter may be plugged.
- C. Plugged handpiece.
- D. Kinked or pinched tubing.
- E. Improper adjustment of water relay.

5. Water coolant is running from handpiece while in holder.

- A. Water pressure is too high.
- B. Air pressure is too low.
- C. Handpiece holder out of adjustment.

6. Water coolant is running continuously.

- A. Purge switch is on (on applicable systems).
- B. Water pressure is too high.
- C. Handpiece holder out of adjustment.
- D. Improper adjustment of water relay.

If you continue to experience difficulties, please call Technical Service Team at 1-800-275-3368.

Installation Instructions

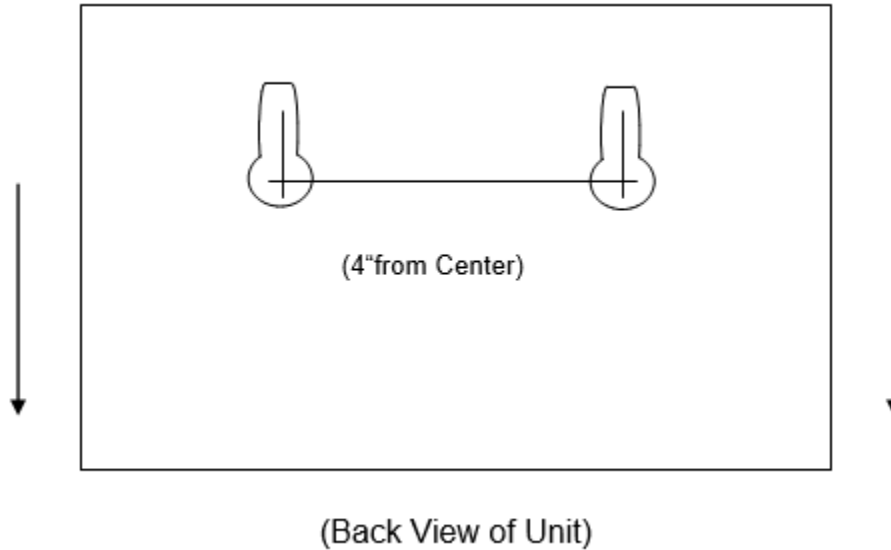

1. Space hanging brackets (screws) 4" from center on the mounting surface.
2. Slide the Control down the hanging brackets (screws).
3. Install the Control's umbilical to the customer supplied utilities (see page 15).

Utility Center Plumbing Layout

(Not to Scale & Not Included)

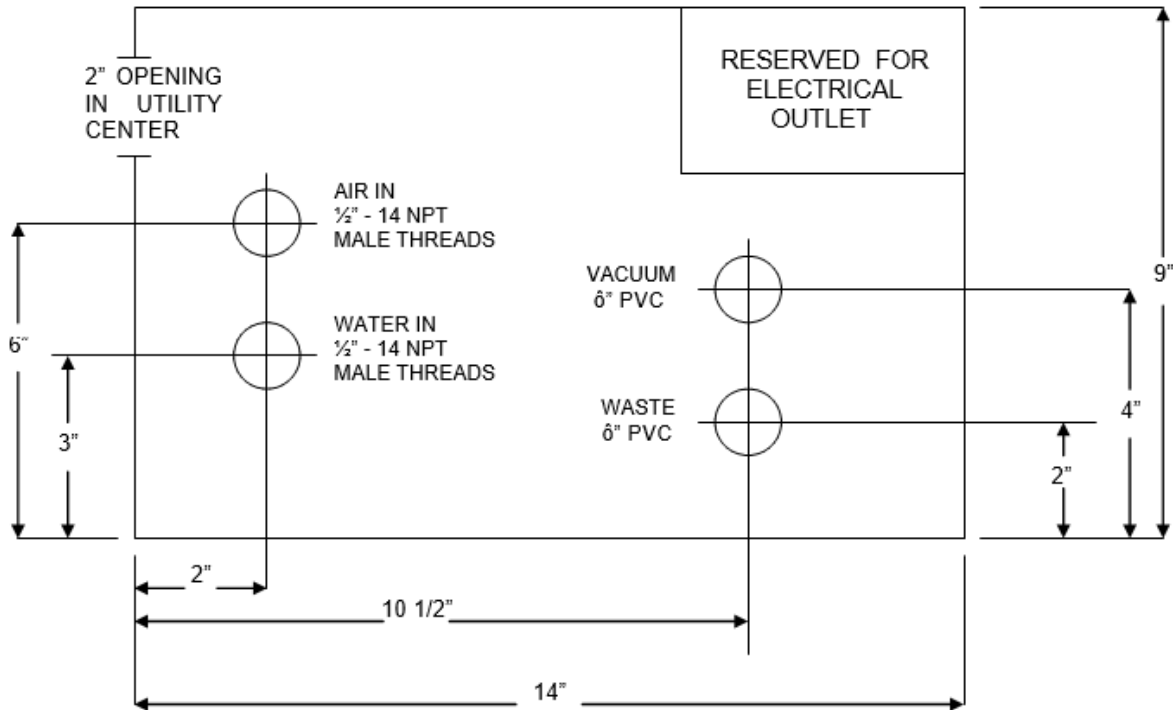

NOTE: All pipes must be terminated 1 inch above floor.
 Position box so that 2" opening faces post side.

Utility Center Tubing Diagram

(Utility Center not included)

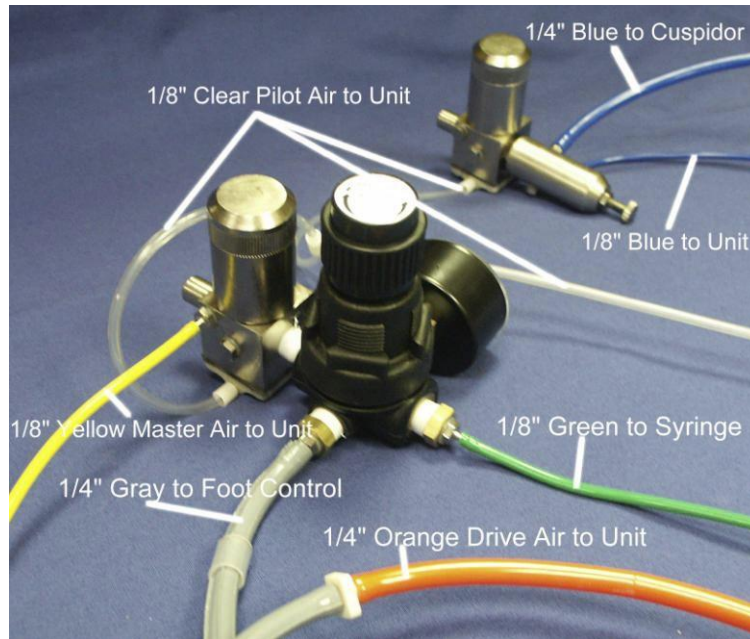

figure 1
Air Side

Air Regulator (Part # 5-070-0111)

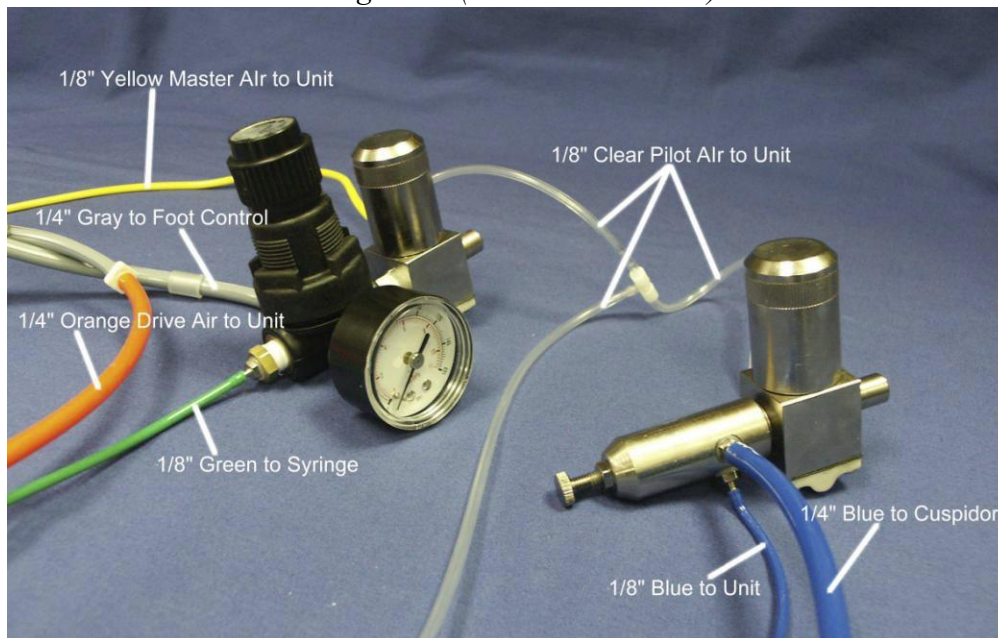

figure 2
Water Side

Water Regulator (Part # 5-070-0103)



1280 SW 27th Ave - Pompano Beach - FL 33069

Toll Free: (800) 275-3368

www.summitdental.com