

Operation
Maintenance
Troubleshooting
Version Dec/17



Viulux LED II Ceiling Mounted Light

TABLE OF CONTENTS

SAFETY REGULATION.....	3
COMPONENTS – HEAD	5
USER'S GUIDE.....	9
OPERATING METHOD – MOVING RANGE	10
MAINTENANCE AND REPAIR.....	11
HEAD TENSION POSITION	11
REPAIR – HEAD (2 AXLE) TENSION CONTROL	13
REPAIR – HEAD (3 AXLE) TENSION CONTROL	14
INSIDE HEAD PARTS REPLACEMENT	15
REPAIR – HORIZONTAL ARM (UP & DOWN) TENSION	16
REPAIR – HORIZONTAL ARM (UP & DOWN) TENSION	18
WIRING MAP & PRODUCT SPECIFICATION	19
MAINTENANCE	20
STORAGE.....	20
WARRANTY.....	21

DEAR CUSTOMER

Congratulations! All of us at Summit Dental Systems want you to know that your Viulux LED II operating light has been built with the finest materials available. The assembly and testing was completed by technicians devoted to making Summit Dental Systems products perform to all prescribed specifications. We appreciate your support and look forward to meeting your future professional needs through our expanding product line.

This manual is a general presentation of your product and it will give you important details to help you solve possible problems. Please read this manual thoroughly and store it for future reference.

SAFETY REGULATION

- Check the condition of the power supply and the connecting parts
- The purpose of the Viulux LED II is to light the inside of patient 's oral cavity during dental treatment
- The installation and use of the Viulux LED II should only be permitted by an expert or licensed person
- Please use caution when using illumination of Viulux LED II for it may cause blindness in the patient.
- Prior to installation, ensure that the power is off and that the power cable is disconnected.
- Should be used with the device(chair unit) that has been permitted and registered as a licensed medical device.
- The Viulux LED II should be installed using a power supply from a single-phase circuit.
- Make sure that the equipment and small parts do not have contact with live parts.
- Inappropriate use of the Viulux LED II may cause harm to the patient or undesired effects.
- In case direction are not followed, safety is not guaranteed.
- Please keep the Viulux LED II and related components out of reach from children.
- Regular disinfection is required in order to prevent contamination.
- In the case where directions are not followed, safety is not guaranteed.
- Do not hang any items from the Viulux LED II device.
- n the event of disposal of the Viulux LED II, please ensure proper disposal of parts (i.e. Iron, rubber, plastic, etc).
- Please wear proper gloves when handling the Viulux LED II.

Caution points during Installation:

- Do not install device near standing water.
- Do not attempt to install the device in adverse conditions (i.e pressure, temperature, humidity, wind).
- Vibration or constant shock of the Viulux LED II may impair the device's use.
- Please do not store near unsafe chemicals or flammable materials.
- Ensure that proper voltage and power consumption is available.
- Make sure that the earthing terminal is tightly connected with the earthing contact of appliance inlet.

After use, ensure the device is properly disinfected to prevent contamination by wiping down the handle head.

Before use, check to the following areas addressed that need special attention:

- All cords are easily accessible.
- Adjust light pattern in accordance with treatment environment.
- Check the condition of the lamp to see if a replacement is warranted.

During use, please pay attention to the following point:

- Always monitor the device for abnormalities.
- If a problem is recognized with the Viulux LED II, please take immediate and appropriate action to ensure the patient's safety.
- Use of the Viulux LED II should only be conducted by expert or licensed individual.

Maintenance information

- Storage : Room Temperature
- Expiry Date : Not applicable

COMPONENTS – HEAD

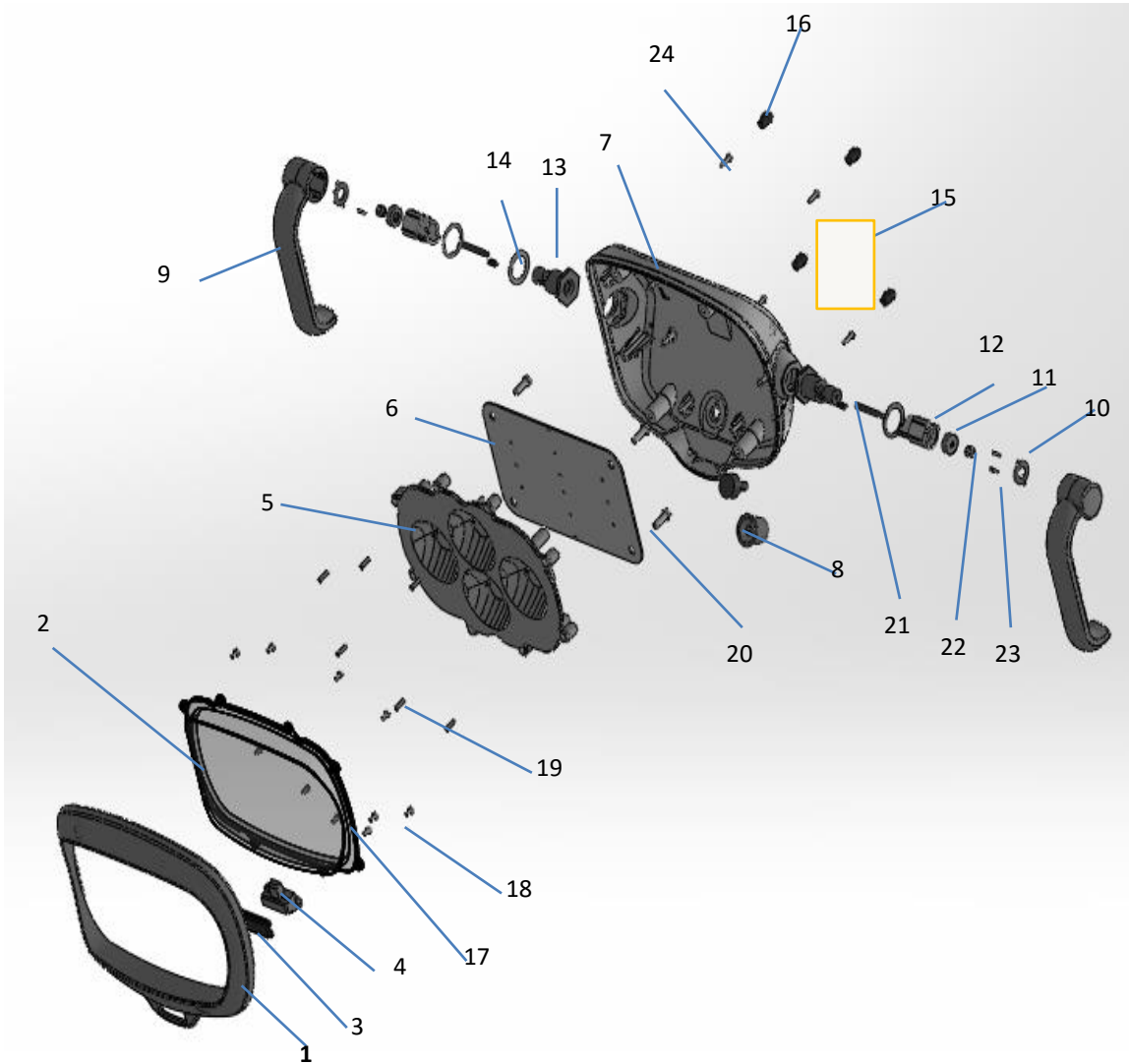

Item	Item Number	Item Description	Qty
1	2-040-0215	Bezel	1
2	2-040-0216	Lens Cover	1
3	2-040-0217	Sense Cover	1
4	3-040-1022	Motion Sense Assembly	1
5	2-040-0218	Reflector	1
6	2-040-0219	LED PCB	1
7	2-040-0220	Top Cover	1
8	2-040-0221	Illumination Control Dial	1
9	2-040-0222	Handle R/L	2
10	4-040-0064	Handel Magnet Washer	2
11	5-040-0059	Handle Magnet	2
12	2-040-0223	Stopper R/L	2
13	2-040-0224	Head Arm Shaft R/L	2
14	4-040-0065	Head Arm Shaft Washer	4
15	8-040-0032	Logo Sticker	1
16	2-040-0225	Bolt Cap	4
17	4-040-0066	Flat Head Screw (M3 X 8L)	2
18	4-040-0067	Round Head Screw (M3 X 8L)	8
19	4-040-0067	Round Head Screw (M3 X 8L)	8
20	4-040-0068	Round Head Screw (M5 X 10L)	4
21	4-040-0069	Socket Set Screw (M4 X 30L)	2
22	4-040-0070	Hexagon Nut (M4)	2
23	4-040-0071	Flat Head Screw (M2 X 8L)	4
24	4-040-0072	Round Head Screw (M3 X 10L)	4

COMPONENTS - HEAD

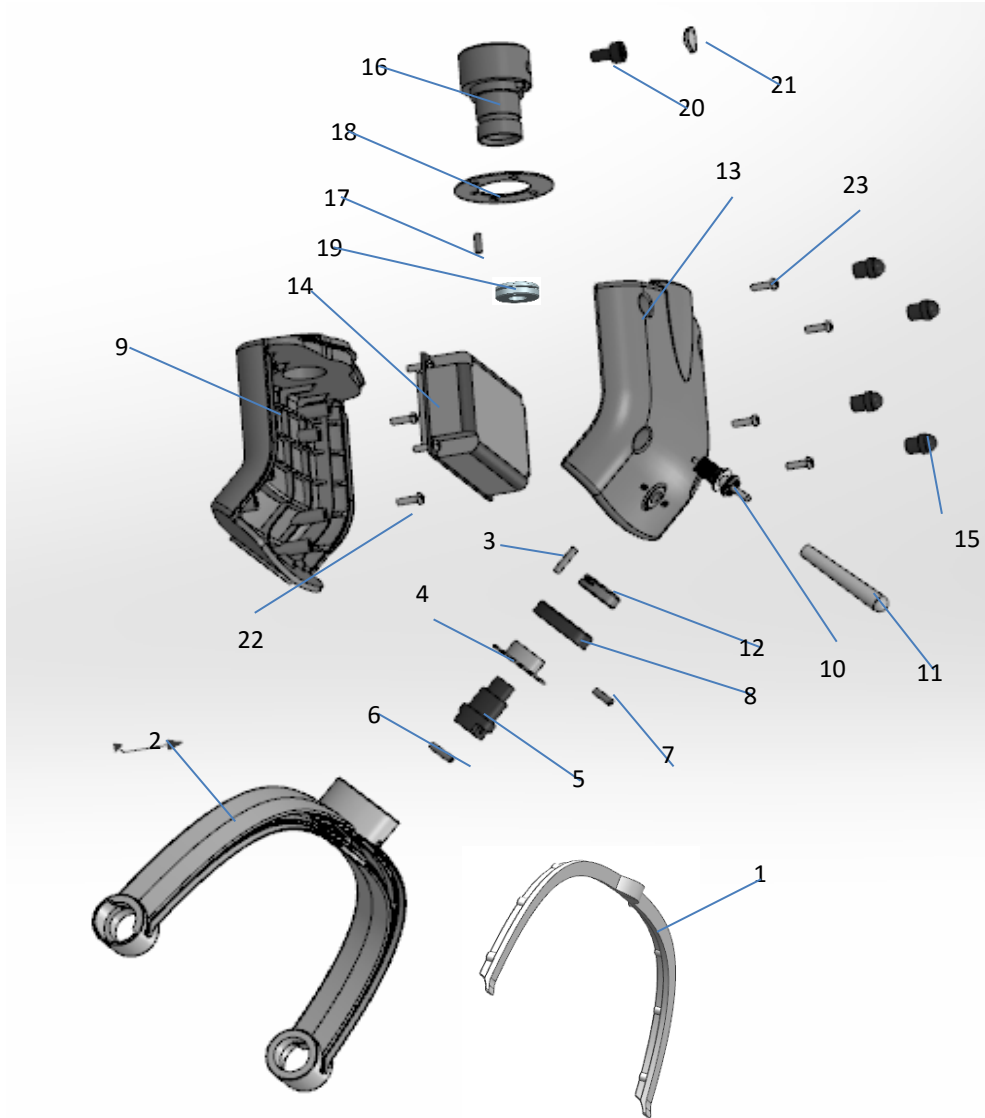

Item	Item Number	Item Description	Qty
1	2-040-0226	First Head Arm Guide	1
2	2-040-0227	First Head Arm Body	1
3	4-040-0073	Head Arm Joint Pin	1
4	4-040-0074	Spindle 1 Washer	1
5	2-040-0228	Spindle 1	1
6	4-040-0075	Spindle Joint Pin	1
7	4-040-0076	Hexagon Socket Button Head Cap Screw	1
8	2-040-0229	Head Arm Joint	1
9	2-040-0230	Second Head Arm Front	1
10	5-040-0060	Switch	1
11	5-040-0061	Power Switch Knob	1
12	4-040-0077	Plain Washer / Disc Spring / M10 Lock Washer / M10 Lock Nut	1
13	2-040-0231	Second Head Arm Rear	1
14	5-040-0062	Controller Board	1
15	2-040-0225	Bolt Cap	4
16	2-040-0232	Spindle 3	1
17	4-040-0078	Second Head Arm Front Pin	1
18	4-040-0079	Spindle 3 Washer	1
19	4-040-0080	Plain Washer / WW20 Wave Washer / M20 Lock Washer / M20 Lock Nut	1
20	4-040-0081	Hexagon Socket Flat Head Cap Screw (M5 X 15L)	1
21	2-040-0233	Head Arm Cap	1
22	4-040-0072	Round Head Screw (M3 X 10L)	
23	4-040-0072	Round Head Screw (M3 X 10L)	

USER'S GUIDE

Product Operating Order

1. The switch requires to be located in the 'ON' on the chair and on the Head Arm.
2. The height of Head can be adjusted to focus a part of treatment region by using the Head handle.
3. Set up the light intensity for treatment using light intensity control dial and sensor detected.
4. During treatment, adjust the position by using the Head Handle.
5. After use, power it off by pressing the power switch or light button of chair unit.

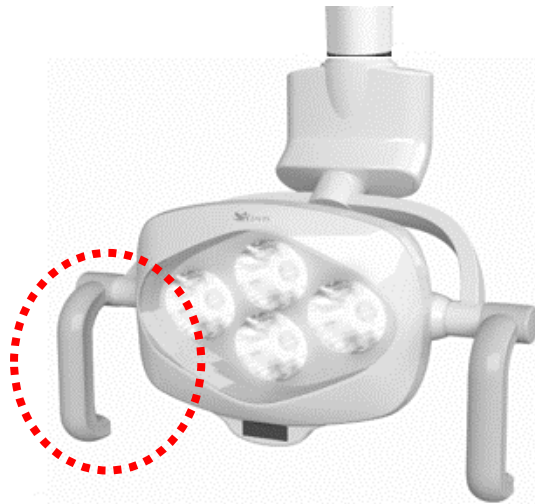

Detachable Handle – using neodymium magnet
- Conveniently detachable, autoclavable, and pasteurizable for sanitary use.

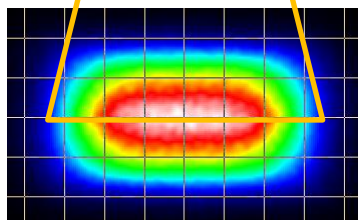

Optimum pattern size: 15cm X 9cm

OPERATING METHOD – MOVING RANGE

HEAD ARM

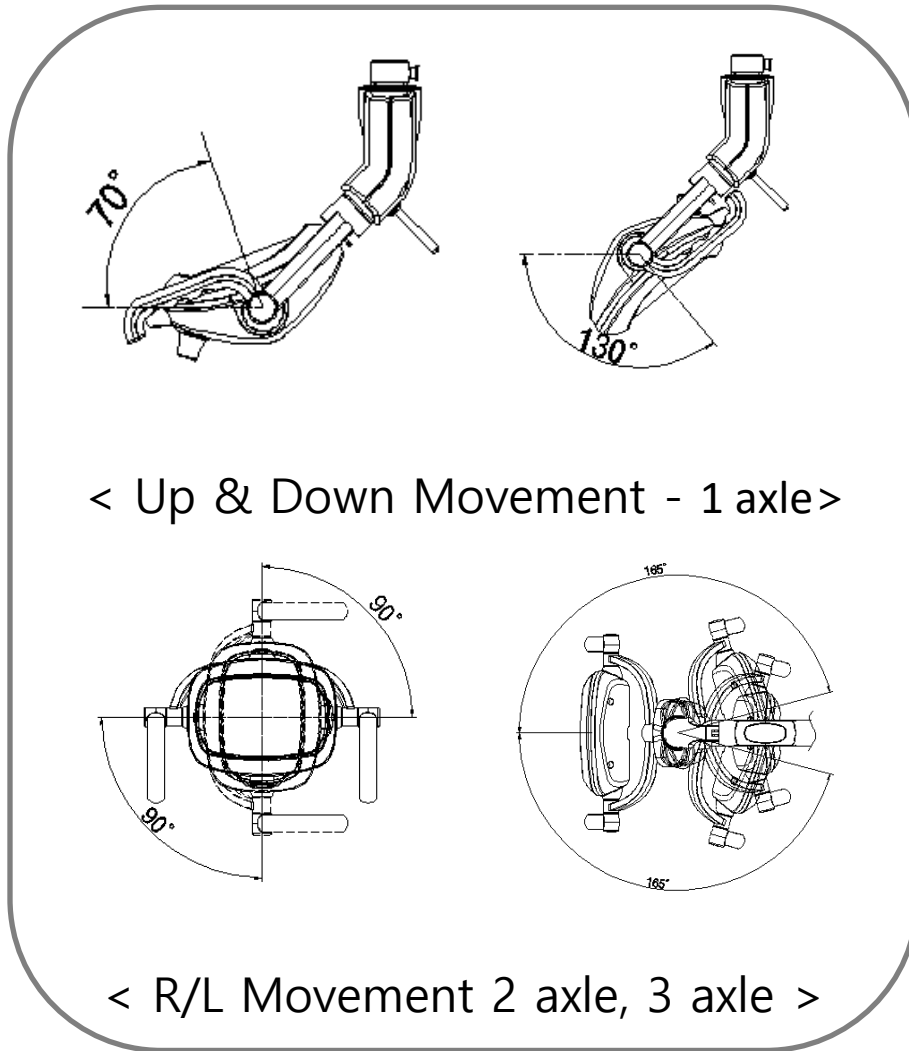



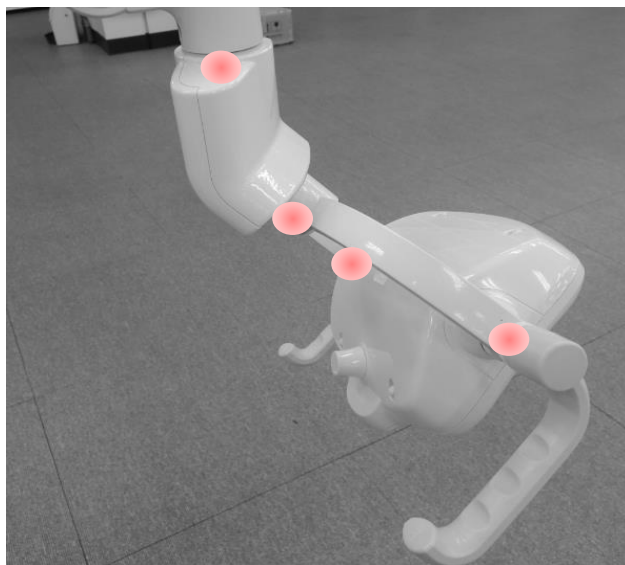

MAINTENANCE AND REPAIR

HEAD TENSION POSITION

Repair – Head (1 axle) tension control

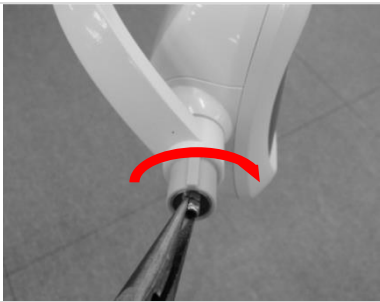



1	<p>Check head 1 axle tension position</p> <p>Check the 2 handles connected R/L Side of first head arm. (neodymium magnet)</p>	
2	<p>Removal R/L Handle</p> <ul style="list-style-type: none"> - Working method: Remove R/L Handle installed on First Head Arm. <p>Caution: Remove handle one by one, use of proper force.</p>	
3	<p>1 axle tension control</p> <ul style="list-style-type: none"> - Tool : long nose pliers - Working Method: Adjust proper tension with long nose pliers. <p>Caution:</p> <ul style="list-style-type: none"> - Fine adjusting should be done by one side. - Use of proper amount force 	
4	<p>Combination</p> <ul style="list-style-type: none"> - Install handle by final step. <p>Caution: Make sure the Handle direction</p>	

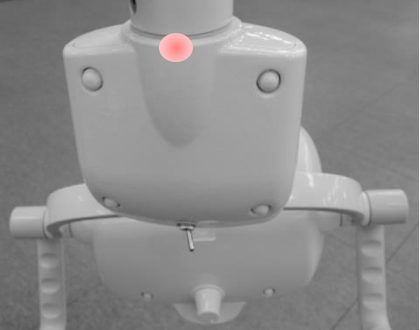
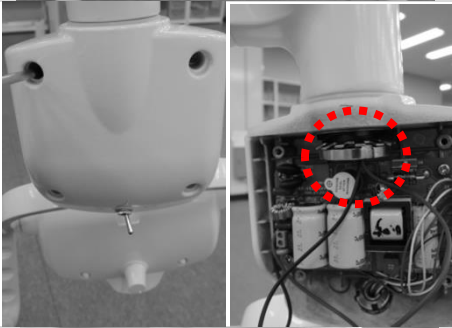

REPAIR – HEAD (2 AXLE) TENSION CONTROL

1	<p>Check head 2 axle tension position</p> <ul style="list-style-type: none"> - Check the joint part of first head am and second head arm. 	
2	<p>Check Head Arm Hole & Bolt Direction</p> <ul style="list-style-type: none"> - Working Method: Face Head Arm to the front side, make sure the side of Head Arm Hole and internal bolt position. 	
3	<p>2 axle tension control</p> <ul style="list-style-type: none"> - Tool: Hexagon wrench(2.5mm) - Working method: Adjust tension by using a Hexagon wrench. 	

REPAIR – HEAD (3 AXLE) TENSION CONTROL

<p>1</p>	<p>Check head 3 axle tension position</p> <ul style="list-style-type: none"> - Check the joint part of Second Head Arm Body. 	
<p>2</p>	<p>Check the lock nut of tension control</p> <ul style="list-style-type: none"> - Tool : Phillips screwdriver - Working Method : Check the Lock nut, Second Head Arm Rear Removal by Phillips screwdriver 	
<p>3</p>	<p>3 axle tension control</p> <ul style="list-style-type: none"> - Tool : Long nose Pliers - Working method: Adjusting tension by Lock nut. 	

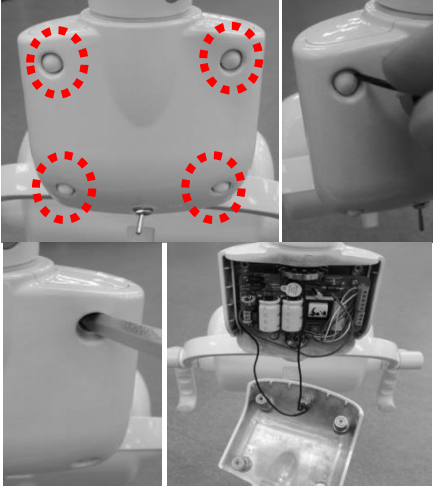
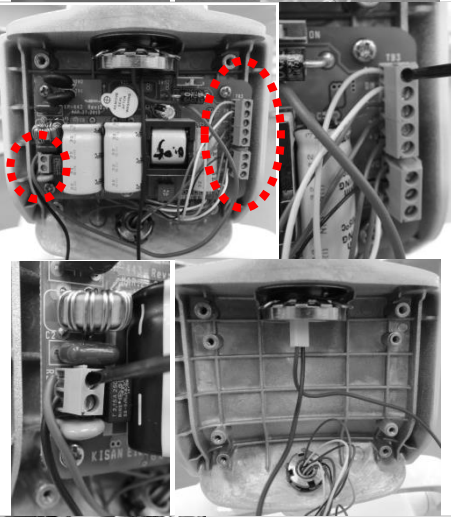
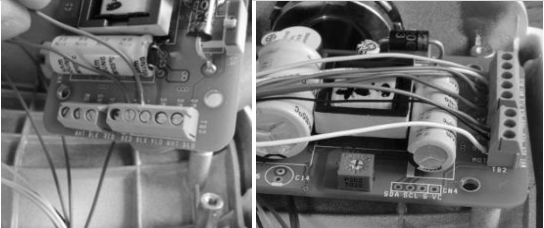
INSIDE HEAD PARTS REPLACEMENT

<p>1</p>	<p>Second Head Arm Rear Disassemble</p> <p>Tool : Phillips screwdriver, (or flat screwdriver)</p> <p>Working Method:</p> <ul style="list-style-type: none"> - Bolt cap of second head arm rear Removal - second head arm rear Removal by '+' driver <p>Caution</p> <ul style="list-style-type: none"> - avoid scratching painted surface. - Be careful not to drop the cover to avoid wire from disconnecting and falling out. 	
<p>2</p>	<p>Harness and Controller B/D Disassemble</p> <p>Tool : Phillips screwdriver, flat screwdriver</p> <p>Working Method</p> <ul style="list-style-type: none"> - Remove Harness by using a flat Driver - Controller Board Removal by phillips Driver 	
<p>3</p>	<p>Replace circuit</p> <p>Working Method</p> <ul style="list-style-type: none"> - Disconnect Wire connecting the circuit PCB. - Replacing circuit PCB (Caution - Wiring) 	
<p>4</p>	<p>Assembly:</p> <ul style="list-style-type: none"> - Reverse steps. 	

REPAIR – HORIZONTAL ARM (UP & DOWN) TENSION CONTROL

Removal Arm Cover (common way)

Tool: flat screw driver(3mm below)

Working Method:

- Disassemble cover using flat screw driver

Caution: use caution with the paint surface avoid breaking the hook on the cover

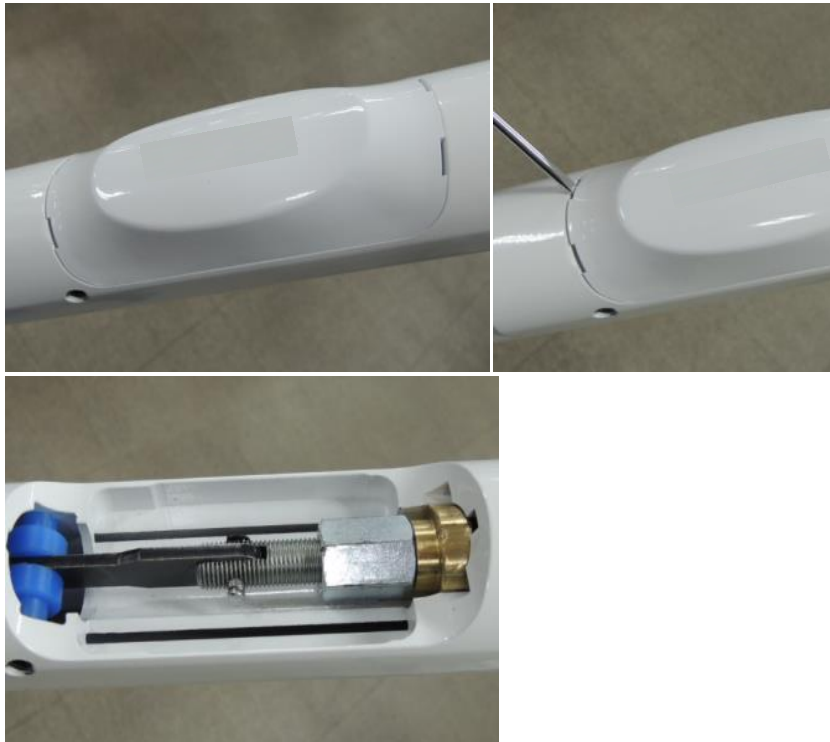

Common Tension Control Method

Tool: Hexagon wrench (3mm)

Working Method

- Lower first horizontal arm as much as possible
- Fix bolts on the both sides as much as possible

Caution:

- Fix the damper bolt
- In case up & down move is not natural, release damper bolt a little bit.



REPAIR – HORIZONTAL ARM (UP & DOWN) TENSION CONTROL

In case of less tension

1. Fix the tension control bolt (refer to the common tension control method)

Tool: Hexagon wrench (3mm)

Working Method:

- Lower first horizontal arm and tighten using hexagon wrench as much as possible and then loosen it a bit.

2. Tension Control

Tool: Long nose Pliers

Working Method: "Tension control "

- Strong : hexagon nut is close from brass shaft
- Weak : hexagon nut is far from brass shaft



3. Final Step

Tool: Hexagon wrench (3mm)

Working method:

- Lower first horizontal arm as much as possible
- Loosen tension control bolt by pipe surface level

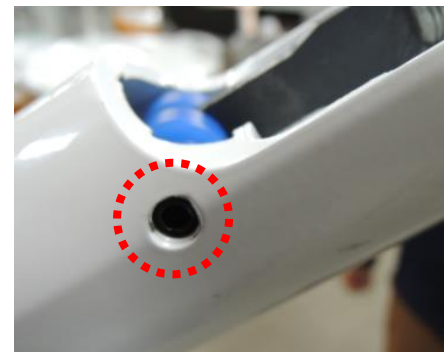

WIRING MAP & PRODUCT SPECIFICATION

Wiring Map

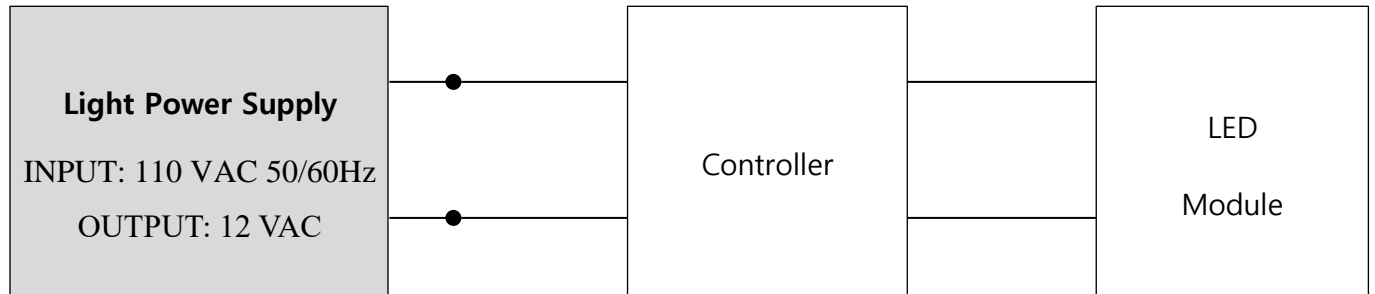

Product Specification

Categories	Light Intensity	Note
Light Intensity	25,000 [Lux]	Based on 70cm distance from the source of light 10%
Color Temperature	5,000 K	± 5%
CRI (Ra)	95	± 3
Focal Distance	70cm	-
Pattern Size	Width: 15cm X – Height: 9cm	-
Power Consumption	12W	-
Power Input	AC 10~18V, 50/60 Hz	-
LED Life Span	50,000 Hours	-

MAINTENANCE

Proper cleaning of device is:

Head Handle and other plastic:

- Be sure to follow the manufacturer's instructions for use

Metal Part (arm pipe & etc.):

- Use a dry cotton swab, moistened cloth to remove surface

LED Lens

- Make sure residual material or debris are not on the surface of the lens
- Remove residual material or debris by lightly rubbing with a micro fiber
- In case of heavy pollution, please contact the manufacturer.

Cleaning and disinfection notice:

- Use rubbing alcohol for disinfection, followed by a clean, soft, free cloth to wipe dry
- Use of thinner or benzene can cause products discoloration.
- Avoid excessive use of disinfectant liquid. (Influx or liquid in the appliance can cause problem.)
- Do not try to clean the device with water, because the IPX0 is unprotected from water damage.

STORAGE

For period not in use, proper storage of the device is required.

1. Remove the power plug from the power outlet!!
2. Clean the body exterior, including the lens surface for dust dirt.
3. Disassemble the product in a accordance with procedure provided by the Disassembly page.
4. Package well to prevent dust and other contaminants. Contamination of parts, especially to the Head can create a decrease in product performance.
5. Store at room temperature in a non-moist environment.
6. Store under care by licensed professional.
7. Avoid storage in areas of past-ridden.

WARRANTY

Summit Dental Systems (SDS) warrants its products against defects in materials or workmanship from the date of shipment to the Buyer as follows:

Summit Dental Systems (SDS) Equipment:

Chairs, Delivery Units, Cuspidors, Lights
 Control Block Diaphragm (part of Delivery Unit)
 All Upholstery, Stools, all Plastic Covers, and Cabinets

Warranty Period:

5 Years
 Lifetime
 1 Year

Summit Dental Systems' sole obligation under the warranty is to provide parts for repair, or at its option, to provide a replacement product (excluding all labor and shipping fees). "In any action, BUYER'S remedies are limited to the warranty described above. BUYER shall not be permitted to claim lost profits, reliance, special, incidental, or consequential damages in any proceedings." The warranty does not cover damage from improper installation or maintenance, accident, or misuse. The warranty does not cover damage resulting from the use of cleaning disinfecting or sterilization chemicals and processes. Failure to follow instructions provided in Summit Dental Systems' Operation and Installation Manuals (Owner's Guides) may void the warranty. In the event Warranty service must be performed to correct any defect, only an authorized Summit Dental Systems dealer may perform any and all warranty repairs. Any repairs by unauthorized dealers, technicians, or repairmen may void the warranty.

- In the case of a defective warranty item, a copy of the replacement invoice, model and serial number of the product under which it was replaced, and a description of symptoms of the defect must be returned with the part within 30 days of the replacement invoice date to Summit Dental Systems, 1280 SW 27th Ave Pompano Beach, FL 33069, USA in order to receive credit. Any and all expenses for freight, labor to perform warranty service, and purchase of spare parts are the responsibility of the buyer. Any fraudulent claims made may void the warranty. Any additional warranty that may be provided by an authorized Summit Dental Systems dealer is the sole responsibility of said dealer.
- SDS reserves the right to make changes or improvements on any products without being required to modify existing equipment in a like manner.

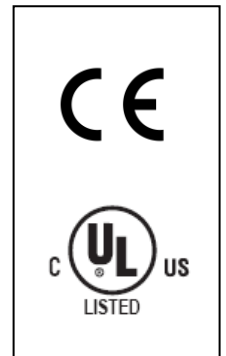

Please complete and retain for your records the following information:

In case of warranty part replacement/repair or when ordering a part, please call your authorized Summit Dental Systems dealer and have the following information available:

Owners' Name:	Phone #:
Model #:	SDS Serial #:
Dealer:	Phone:
	Purchase Date:



1280 SW 27th Ave - Pompano Beach - FL 33069

Toll Free: (800) 275-3368

www.summitdental.com